

NOTE: BREAK ALL CORNERS WITH 0.015" (.38 MM) RADIUS UNLESS OTHERWISE NOTED. STANDARD TOLERANCES TO APPLY UNLESS OTHERWISE SPECIFIED.

CUSTOMER	<b>CAN ART STD.</b>	DIE No.	EH05956	REV. No.	<b>1</b>
DESCRIPTION	CUSTOMER PART No.	QUOTE No.	PROPOSAL No.		
2.000" x 1.000" x 0.120" THK. RECT. TUBE		L10-0085	H-58997		

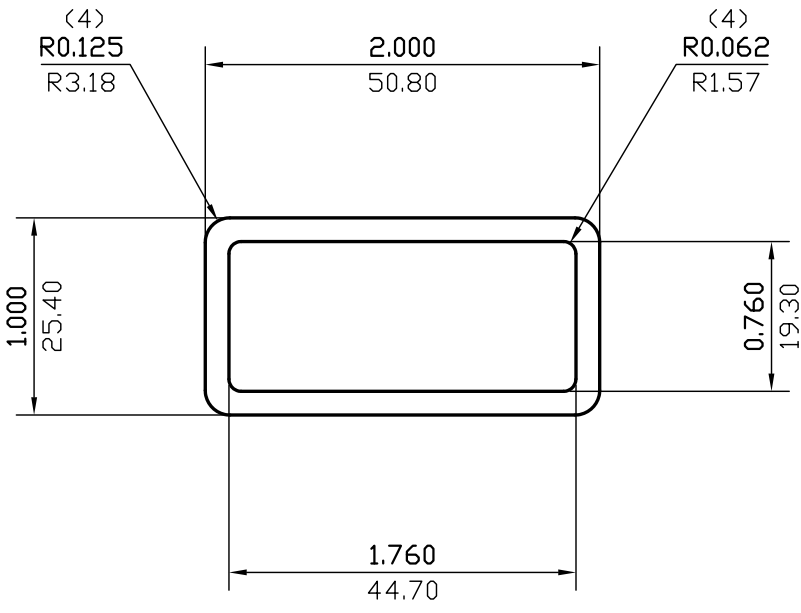

WALL THICKNESS 0.120 (3.05) EXCEPT AS SHOWN

DATE	REV	DESCRIPTION	BY		
03/15/23	1	REMOVED ALLOY	JASON		
EST.AREA	0.652	IN. <sup>2</sup>	EST.AREA	420.833	MM. <sup>2</sup>
EST.WT.	0.783	LBS/FT.	EST.WT.	1.165	KG/M.
EST.PER.	10.719	IN.	EST.PER.	272.261	MM.
OUT PER.	5.785	IN.	OUT PER.	146.9	MM.
C.C.D.	2.154	IN.	C.C.D.	54.710	MM.
FINISH	M/F		ALLOY		
CKD BY	FACTOR 14	SCALE 1:1	DWN BY J.T.	DATE 01/25/2010	

# CAN ART

428 JUTRAS DRIVE S.  
WINDSOR, ON N8N 5C5  
TEL. NO. (519) 727-4399  
FAX NO. (519) 727-6434  
WEB: www.canart.com

ALUMINUM EXTRUSION INC.

THIS DRAWING IS NOT NECESSARILY A COPY OF YOUR ORIGINAL. PLEASE APPROVE DIMENSIONS AND TOLERANCES INDICATED. CAN ART ASSUMES NO RESPONSIBILITY EITHER TECHNICAL OR LEGAL FOR HAVING THIS SHAPE MADE. THE CUSTOMER AGREES TO FULLY PROTECT CAN ART ALUMINUM FROM CLAIMS OF OTHERS RESULTING FROM THIS SHAPE.

SIGNED: \_\_\_\_\_ DATE: \_\_\_\_\_